

PARTS LIST

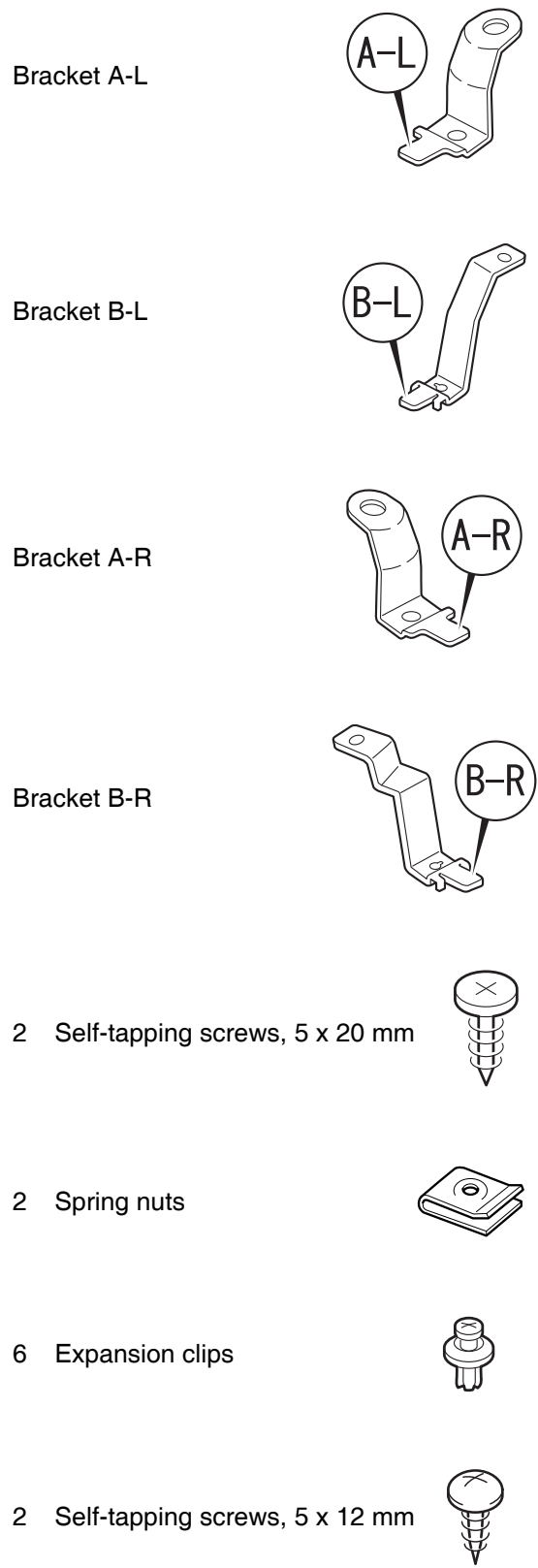

4 Black films

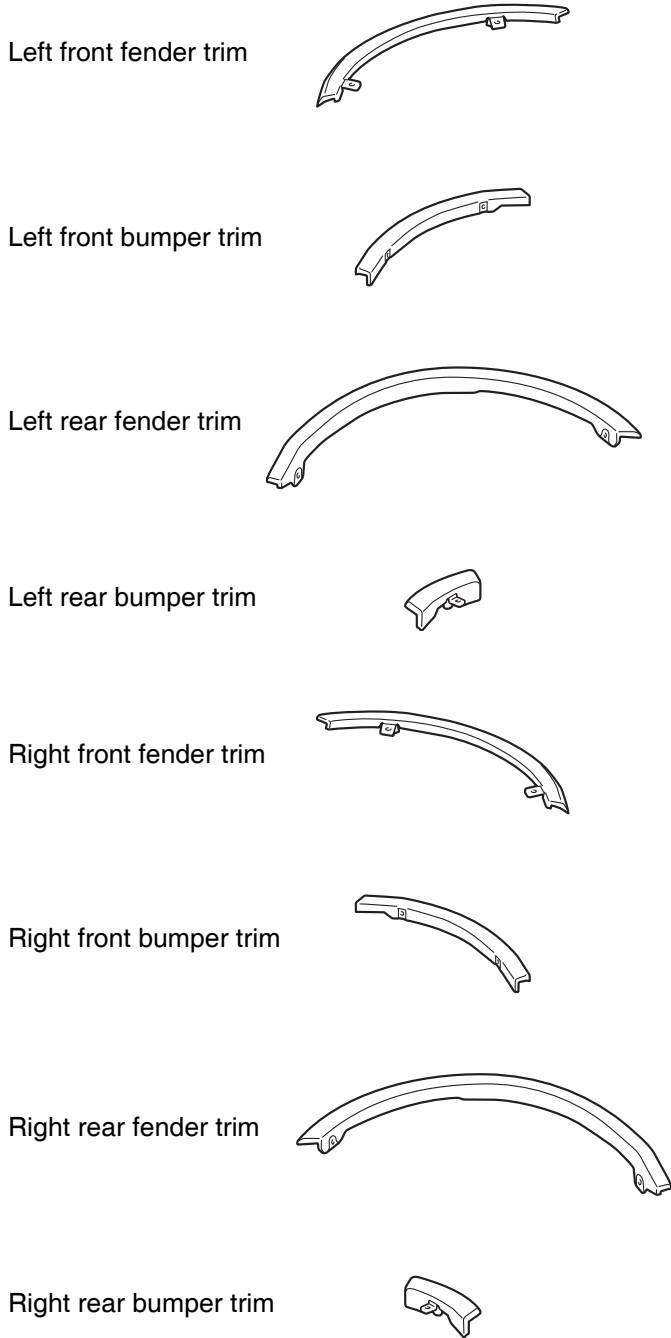
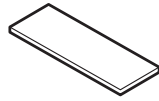

10 Alcohol swabs

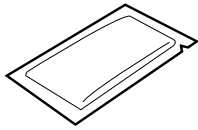

Alcohol swab information

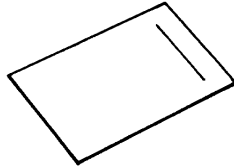

TOOLS AND SUPPLIES REQUIRED

Stubby Phillips screwdriver
Flat-tip screwdriver
Ratchet
10 mm Socket
Masking tape
Tape measure
Rubber roller (T/N MHLE54D)

INSTALLATION

Client Information: The information in this installation instruction is intended for use only by skilled technicians who have the proper tools, equipment, and training to correctly and safely add equipment to your vehicle. These procedures should not be attempted by “do-it-yourselfers.”

NOTE:

- Be careful not to damage the painted surfaces of the body when installing the fender trim
- This fender trim kit should be installed only if the ambient air temperature is 15°C (60°F) or above.
- To allow the adhesive to cure, do not wash the vehicle for 24 hours.
- These instructions show the left fender trim pieces being installed; the same procedure applies to installing the right fender trim pieces.
- This fender trim kit cannot be installed on a vehicle equipped with a full nose mask.

Installing the Left Front Bumper Trim

1. Remove the self-tapping screw from the front bumper.

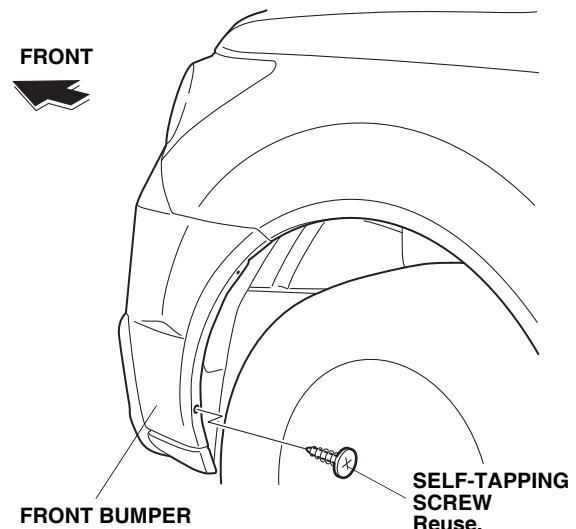

2. Using an alcohol swab, thoroughly clean the area where the left front bumper trim will attach.

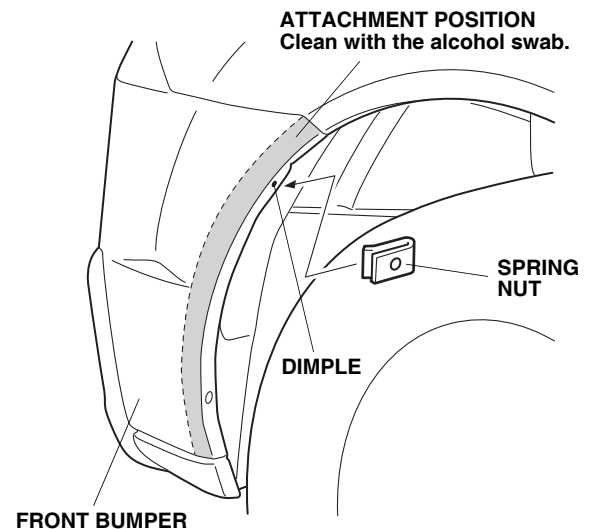

3. Locate the dimple in the front bumper. Slide a spring nut over the dimple.

4. Peel back 25 mm (1 in.) of the adhesive backing, and attach it to the front of the left front bumper trim with masking tape. Remove the small piece of adhesive backing from the left front bumper trim.

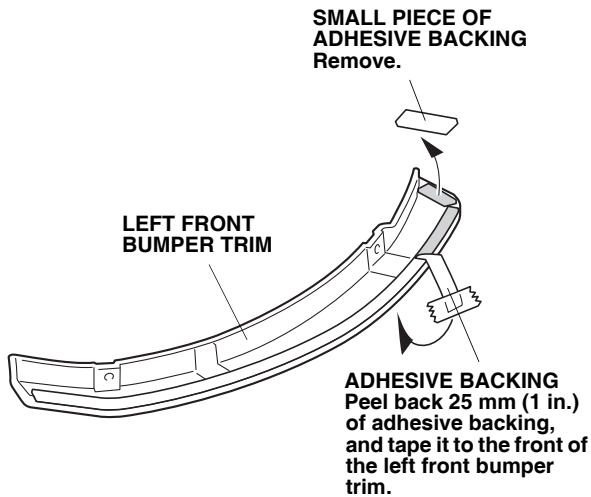

5. Position the left front bumper trim on the front bumper, and align it with the top edge of the front bumper. Install one self-tapping screw and one 5 x 20 mm self-tapping screw through the left front bumper trim, but do not tighten them yet.

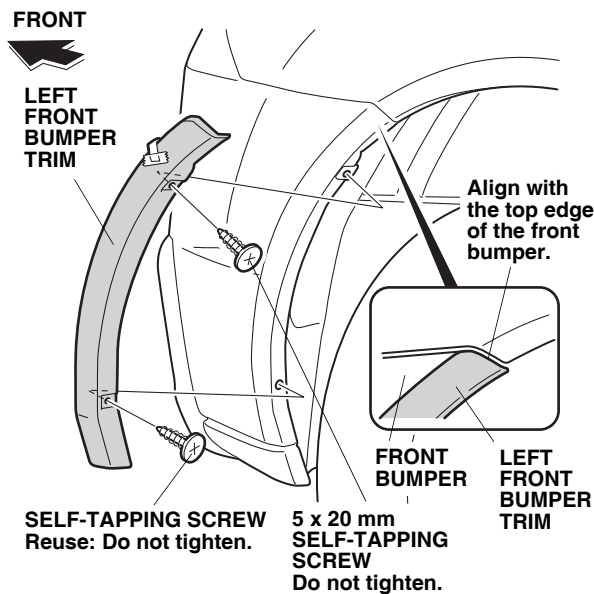

6. Slowly and carefully peel the adhesive backing from the left front bumper trim. After removing the adhesive backing, press the left front bumper trim firmly against the front bumper with the palms of your hands, particularly at the ends, for 30 seconds.

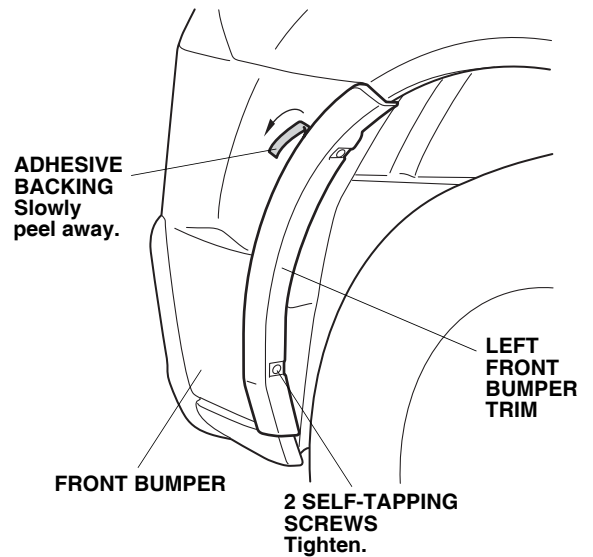

7. Tighten the two self-tapping screws installed in step 5.

Installing the Left Front Fender Trim

8. Turn the steering wheel fully counterclockwise.

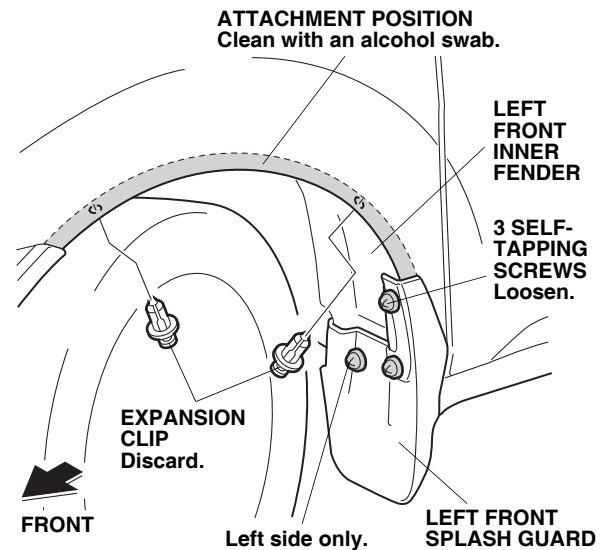

9. Remove the two expansion clips that fasten the left front inner fender, and loosen the three self-tapping screws that fasten the left front splash guard.
10. Using an alcohol swab, thoroughly clean the area where the left front fender trim will attach.

- Using an alcohol swab, thoroughly clean the area where the black film will attach.

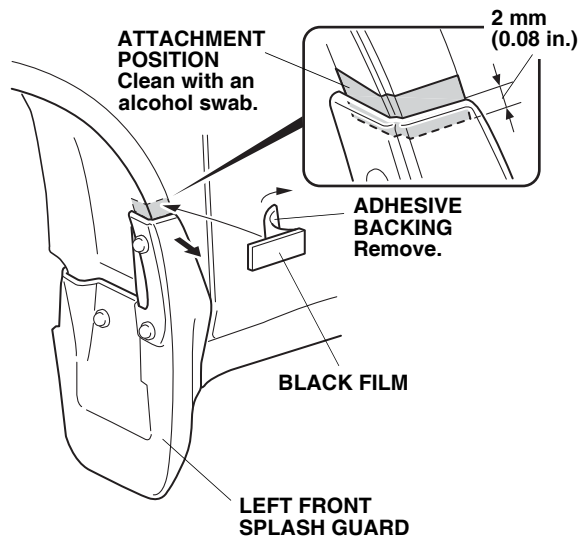

- Remove the adhesive backing from the black film. Pull the top of the left front splash guard out toward you, and attach the black film at the indicated position.
- While holding the left front splash guard against the left front inner fender, tighten the self-tapping screws in the order shown.

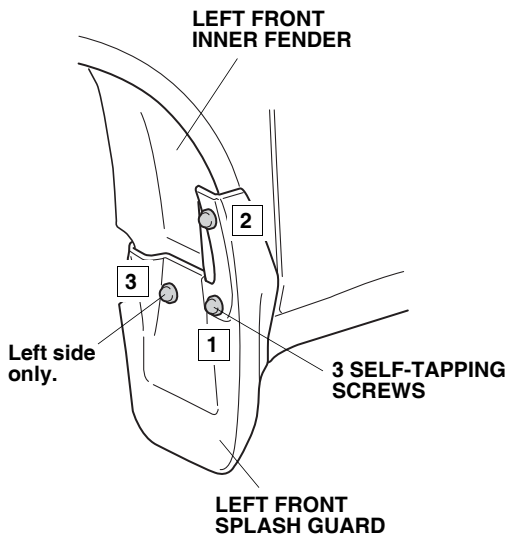

- Peel back 25 mm (1 in.) of the adhesive backings, and attach them to the front of the left front fender trim with masking tape. Remove the small piece of adhesive backing from the left front fender trim.

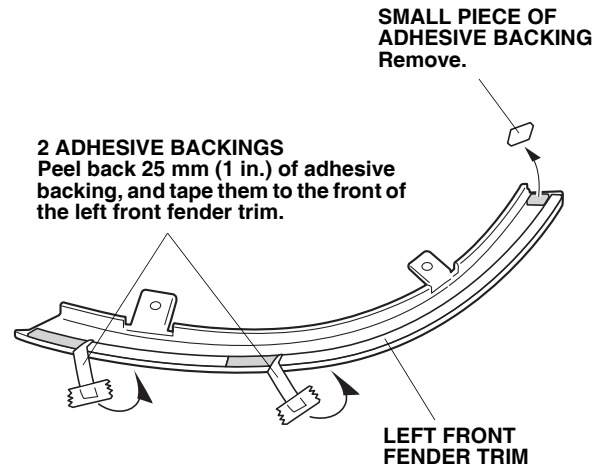

- Position the left front fender trim on the left front fender, and align it with the front edge of the left front fender. Install two new expansion clips through the left front fender trim.

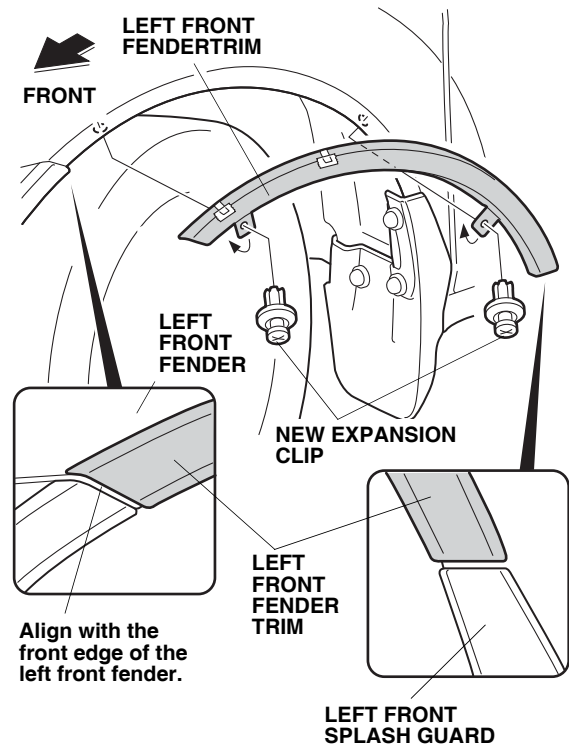

- Slowly and carefully peel the adhesive backings from the left front fender trim. After removing all of the adhesive backings, press the left front fender trim firmly against the left front fender with the palms of your hands, particularly at the ends, for 30 seconds.

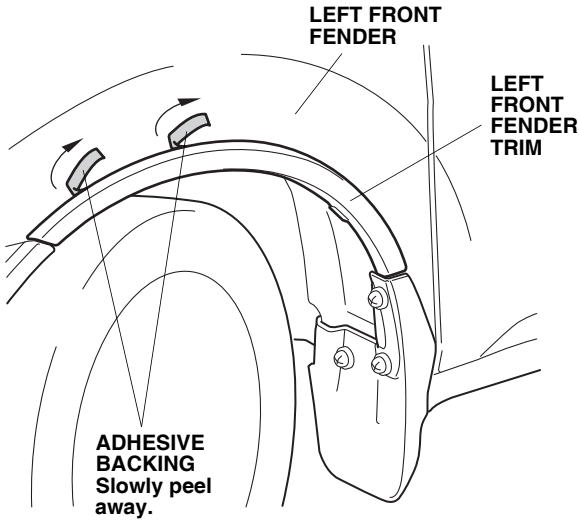

- Using a rubber roller, apply pressure against the left front bumper trim and left front fender trim while rolling from one end to the other.

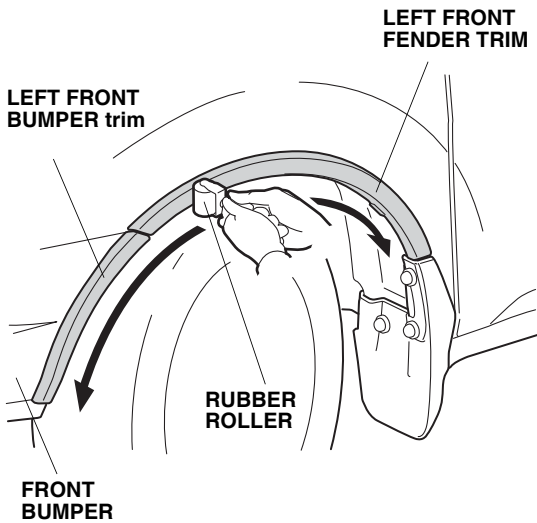

Installing the Left Rear Bumper Trim

- Remove the self-tapping screw that fastens the rear bumper to the left fenderwell.

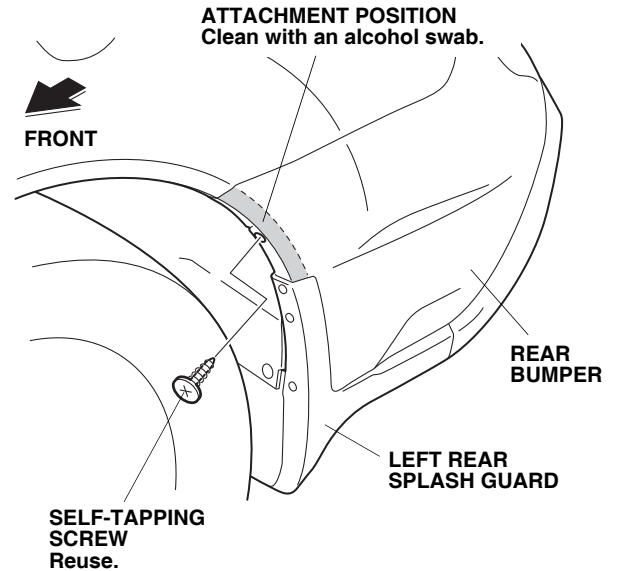

- Using an alcohol swab, thoroughly clean the area where the left rear bumper trim will attach.
- Remove the four self-tapping screws and one expansion clip that fasten the left rear splash guard.

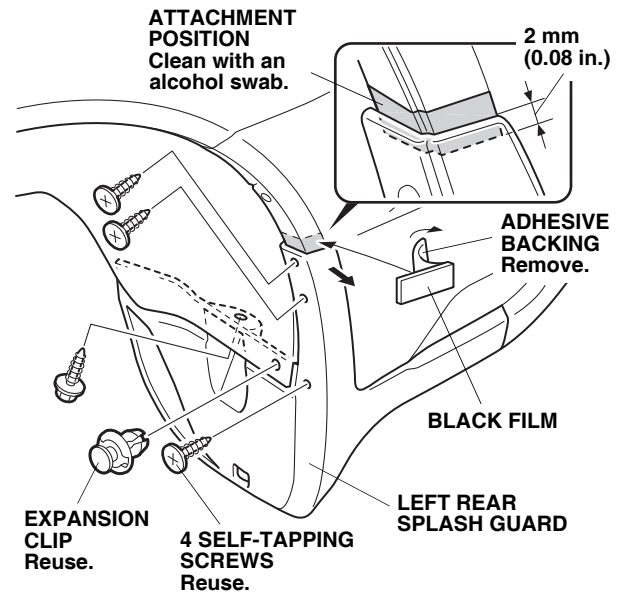

- Using an alcohol swab, thoroughly clean the area where the black film will attach.
- Remove the adhesive backing from the black film. Pull the top of the left rear splash guard out toward you, and attach the black film at the indicated position.

23. Reinstall the four self-tapping screws. Do not tighten the self-tapping screws yet.

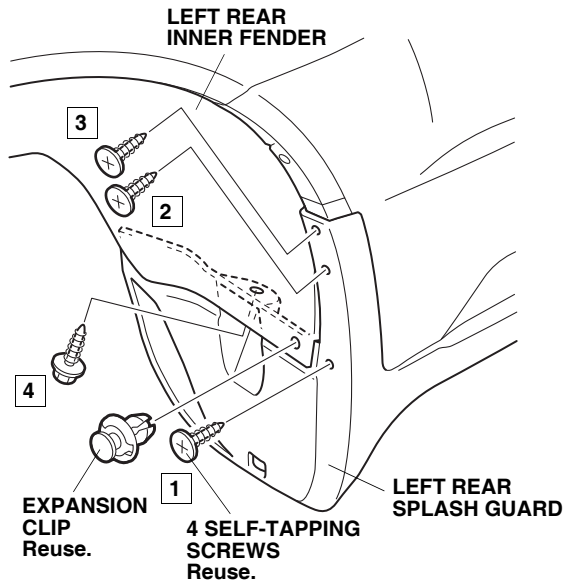

24. While holding the left rear splash guard against the left rear inner fender, tighten the self-tapping screws in the order shown. Reinstall the expansion clip.
25. Peel back 25 mm (1 in.) of the adhesive backing, and attach it to the front of the left rear bumper trim with masking tape. Remove the two small pieces of adhesive backing from the left rear bumper trim.

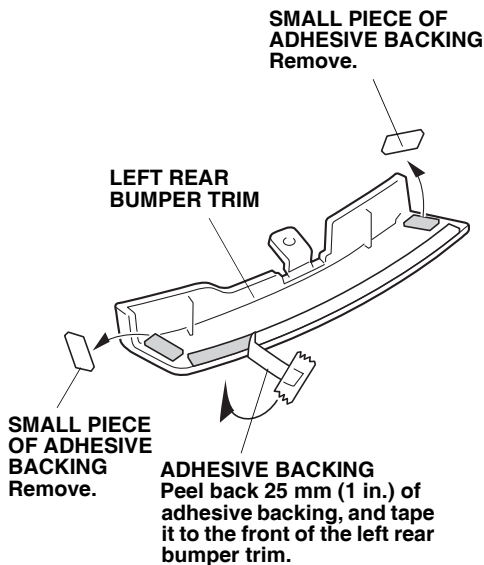

26. Position the left rear bumper trim on the rear bumper, and align it with the top edge of the rear bumper. Install the self-tapping screw through the left rear bumper trim, but do not tighten it yet.

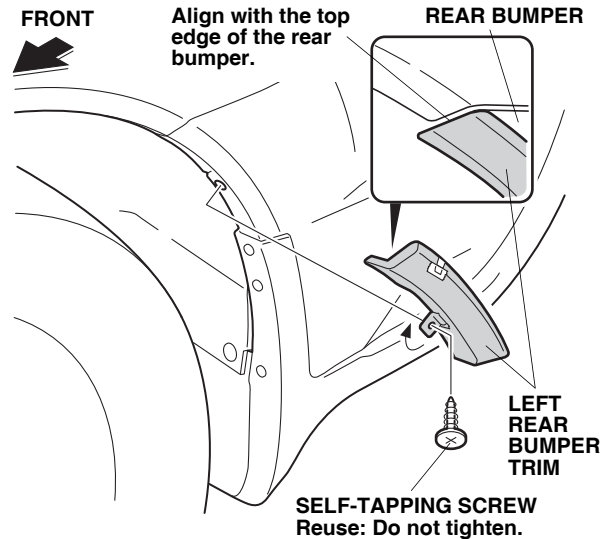

27. Slowly and carefully peel the adhesive backing from the left rear bumper trim. After removing the adhesive backing, press the left rear bumper trim firmly against the rear bumper with the palms of your hands, particularly at the ends, for 30 seconds.

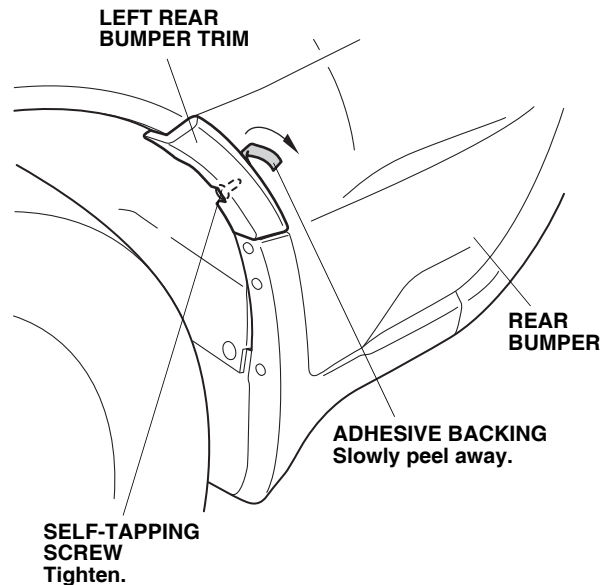

28. Tighten the self-tapping screw installed in step 26.

Installing the Left Rear Fender Trim

29. Remove the expansion clip and bolt from the left rear inner fender.

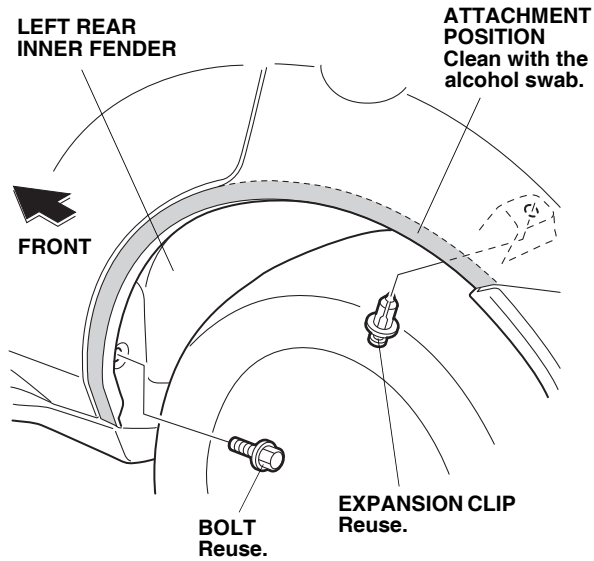

30. Using an alcohol swab, thoroughly clean the area where the left rear fender trim will attach.
31. Use the bolt to install bracket A-L with the tab behind the metal flange, but do not tighten it yet.

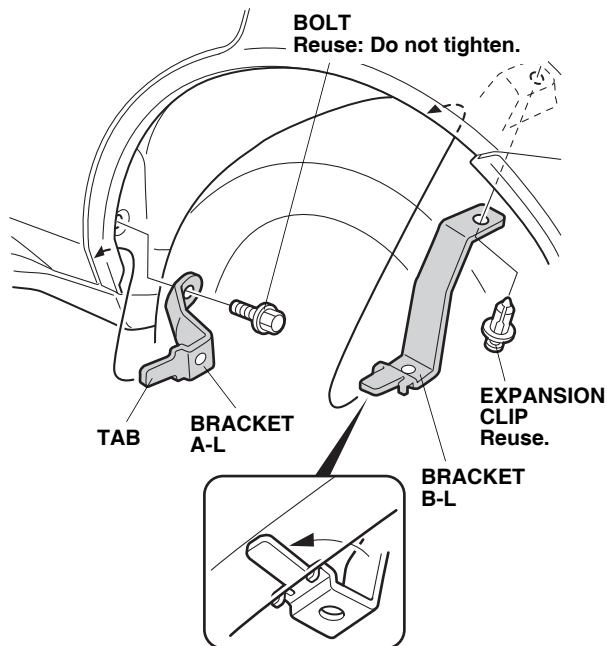

32. Install bracket B-L using the expansion clip.

33. Peel back 25 mm (1 in.) of two adhesive backings, and attach them to the front of the left rear fender trim with masking tape. Remove the two small pieces of adhesive backing from the left rear fender trim.

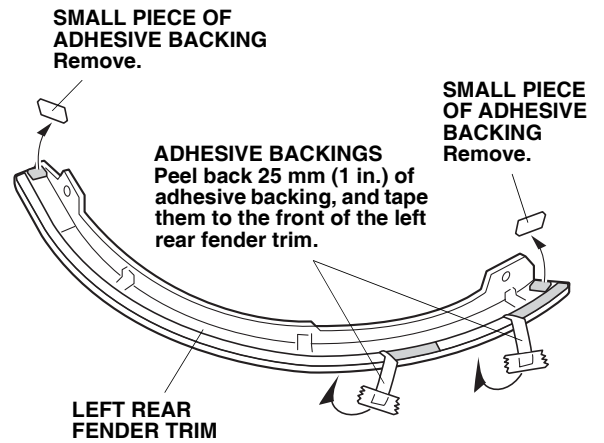

34. Position the left rear fender trim on the left rear fender as shown.

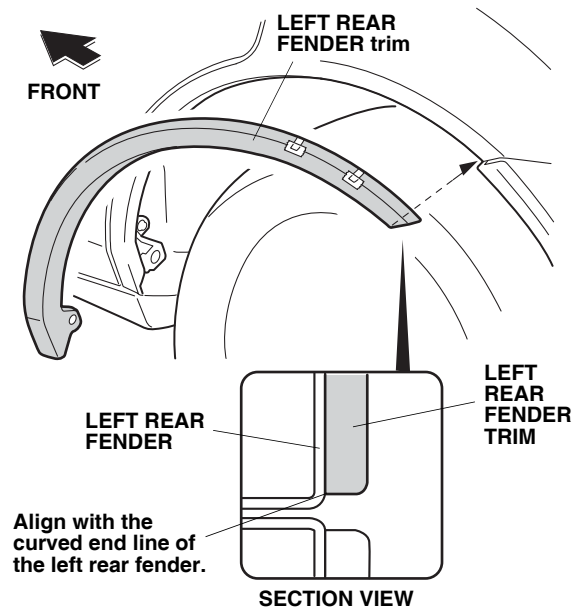

35. Align the hole in bracket A-L with the hole in the left rear fender trim, and tighten the bolt installed in step 31.

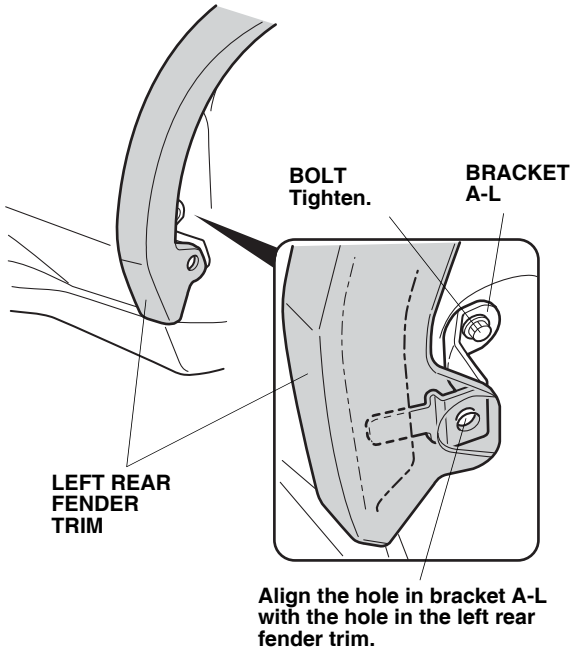

36. Install one 5 x 12 mm self-tapping screw and a new expansion clip through the holes in the left rear fender trim and the brackets A-L and B-L. Do not tighten the 5 x 12 mm self-tapping screw yet.

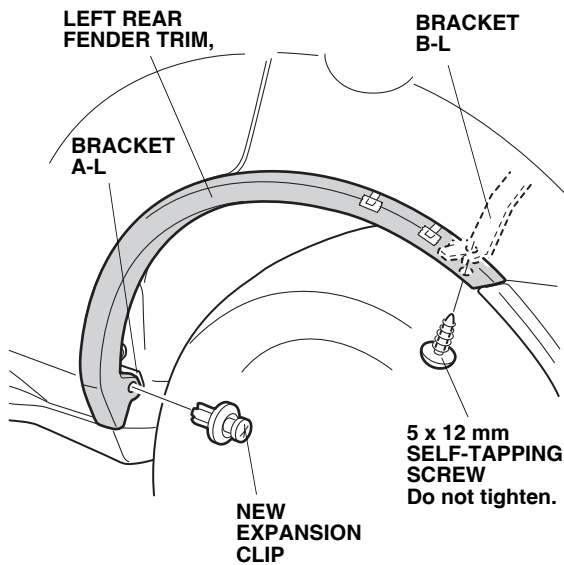

37. While pushing up on the left rear fender trim, slowly and carefully peel the adhesive backings from the left rear fender trim. After removing all of the adhesive backings, press the left rear fender trim firmly against the left rear fender with the palms of your hands for, particularly at the ends, for 30 seconds.

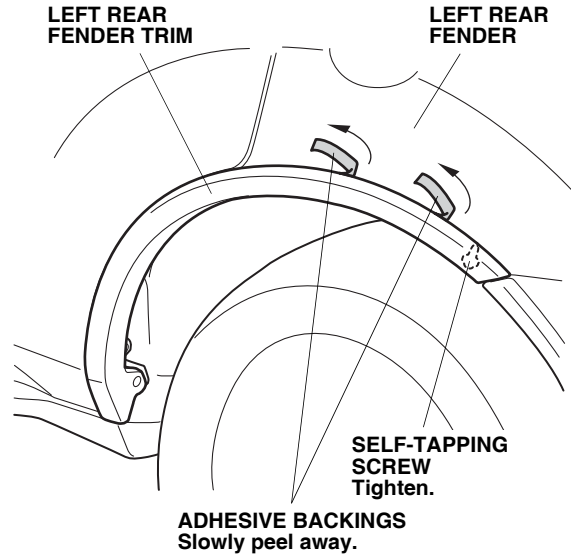

38. Tighten the self-tapping screw installed in step 36.
39. Using a rubber roller, apply pressure against the left rear fender trim and left rear bumper trim while rolling from one end to the other.

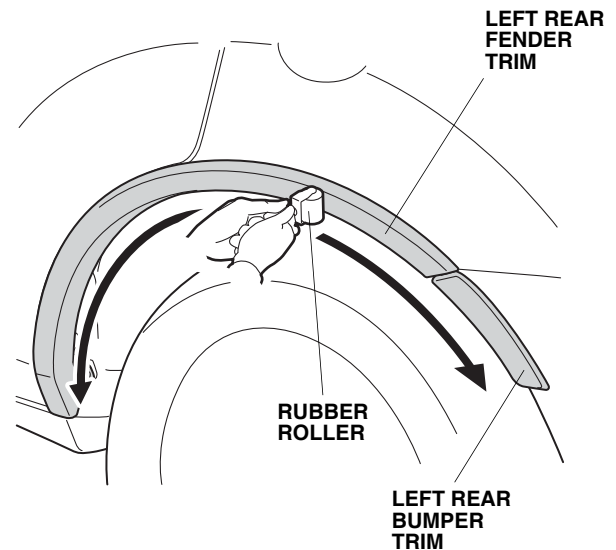

40. Repeat steps 1 through 39 to install the fender trim on the right side of the vehicle (Turn the steering wheel all the way clockwise in step 8).